

Product Specification

ELV-W-Series Submersible Sump Pump with OilTector® Control

ELV250W 1/3 hp

ELV280W 1/2 hp

ELV290W 3/4 hp

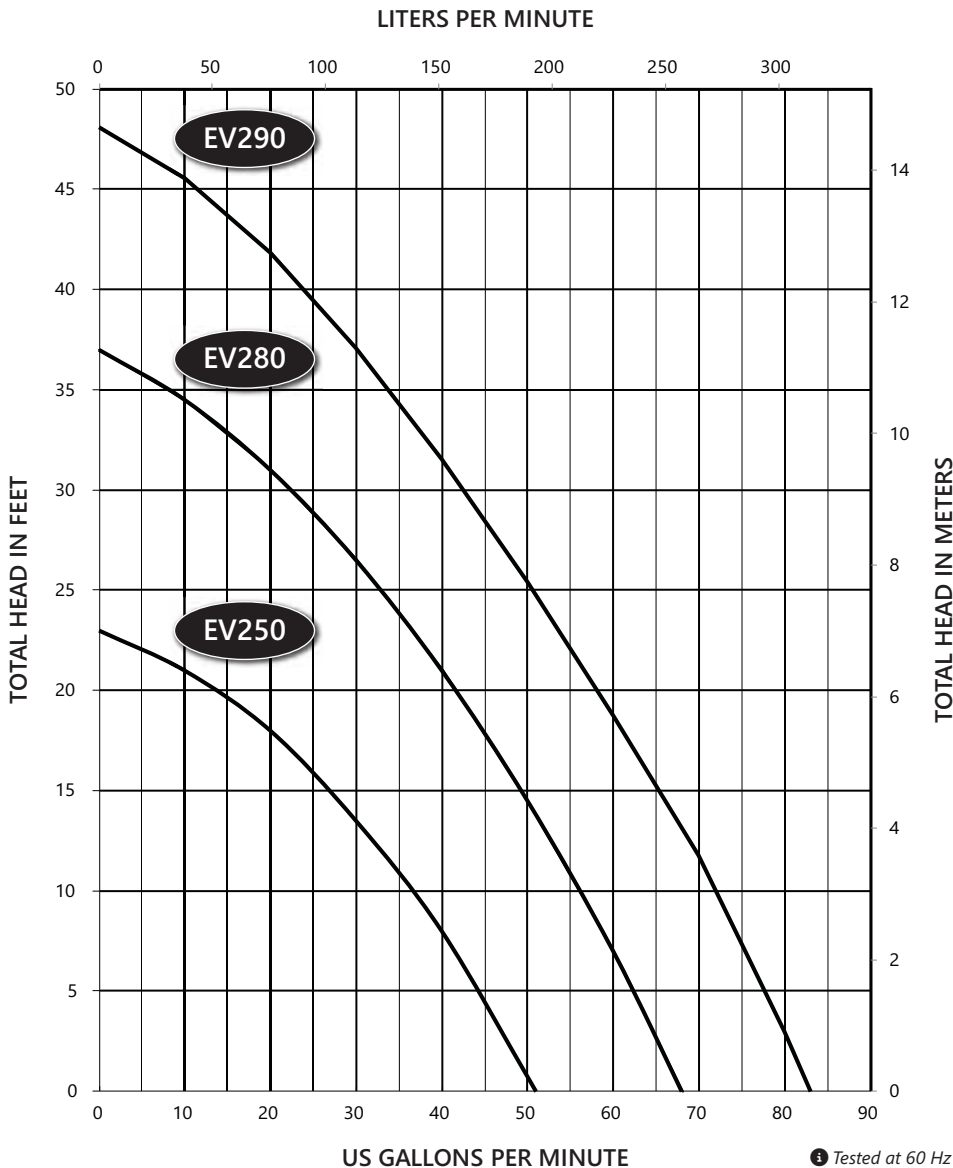

ELV-W-Series Dimensional Data

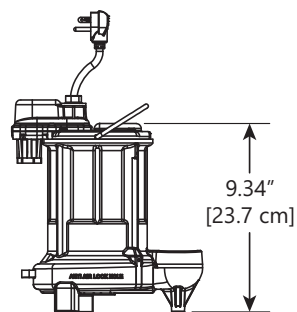
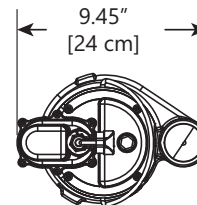
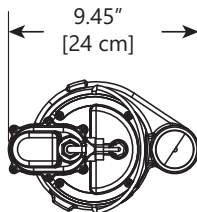
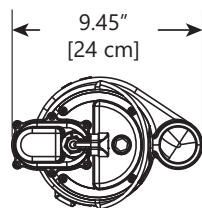

EV250

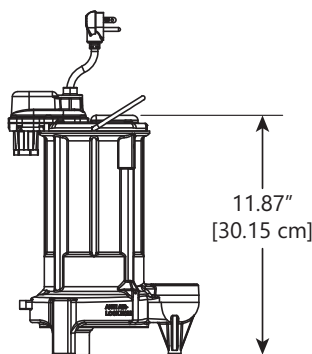

EV280

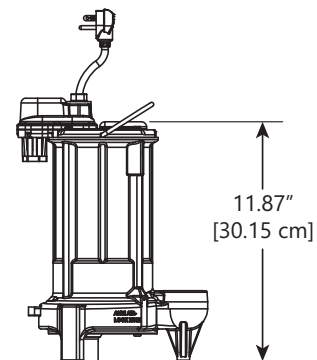

EV290

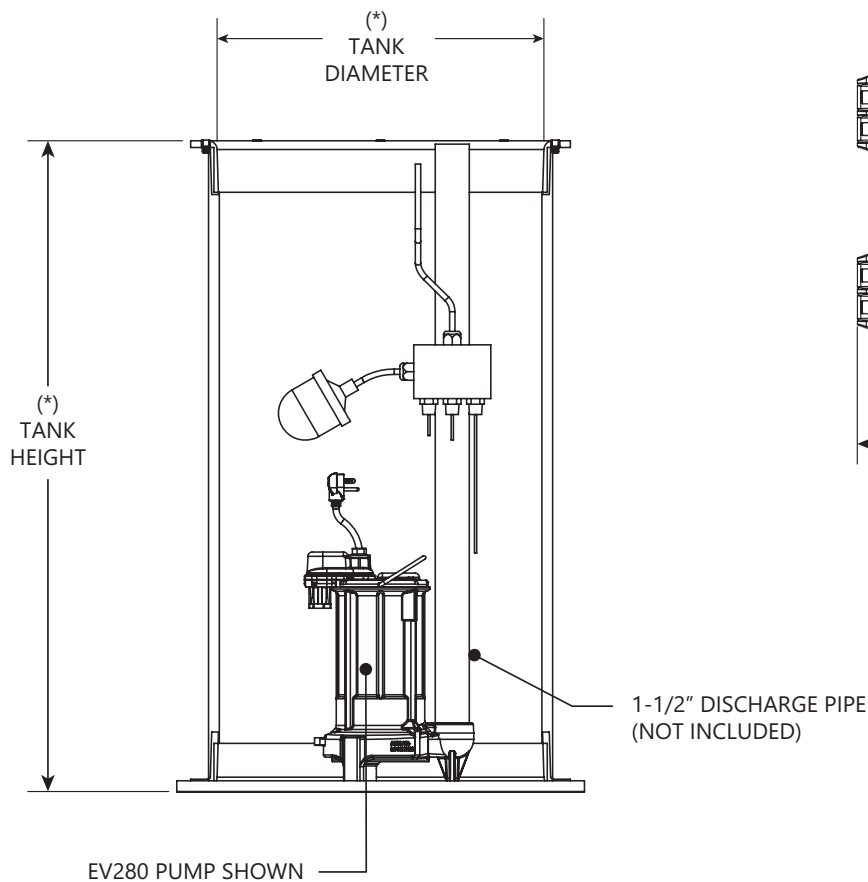

EV280 PUMP SHOWN

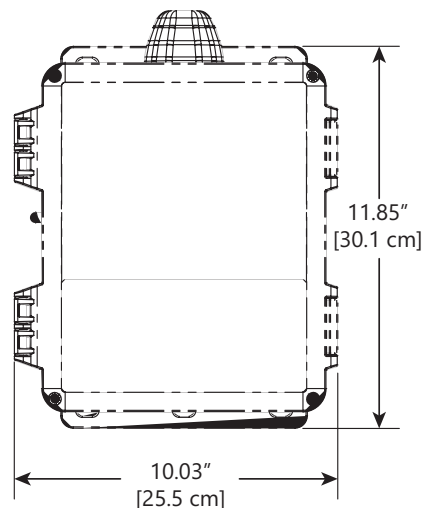

CONTROL PANEL

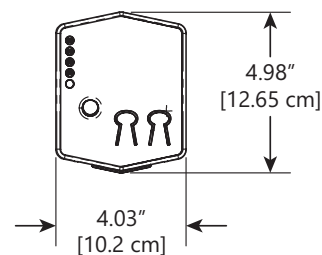

REMOTE ALARM

PRESET LEVEL SENSOR

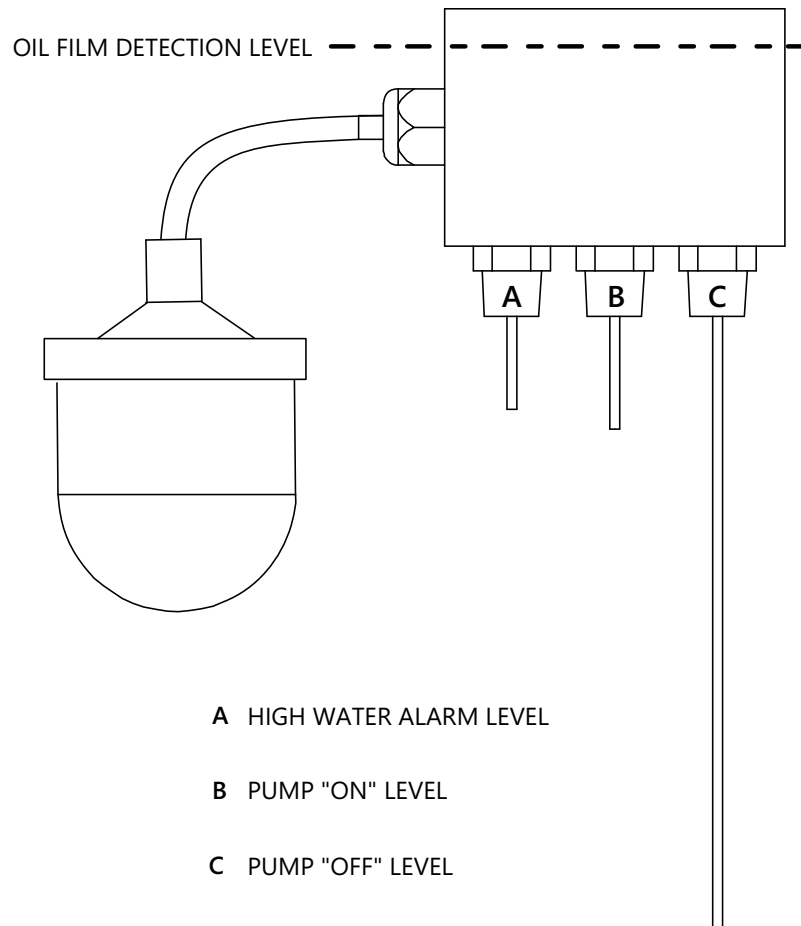

ELV-W-Series Electrical Data

MODEL	HP	VOLTAGE	PHASE	FULL LOAD AMPS	LOCKED ROTOR AMPS	THERMAL OVERLOAD TEMP	STATOR WINDING CLASS	CORD LENGTH [FT]	DISCHARGE	AUTOMATIC
ELV250W	1/3	115	1	5.2	8	105°C / 221°F	B	25	1-1/2"	YES WITH CONTROL
ELV250W-06	1/3	115	1	5.2	8	105°C / 221°F	B	6	1-1/2"	YES WITH CONTROL
ELV280W	1/2	115	1	8.0	23	105°C / 221°F	B	25	1-1/2"	YES WITH CONTROL
ELV280W-06	1/2	115	1	8.0	23	105°C / 221°F	B	6	1-1/2"	YES WITH CONTROL
ELV280HVW	1/2	208-230	1	4.0	12.5	105°C / 221°F	B	25	1-1/2"	YES WITH CONTROL
ELV280HVW-06	1/2	208-230	1	4.0	12.5	105°C / 221°F	B	6	1-1/2"	YES WITH CONTROL
ELV290W	3/4	115	1	10.4	24	120°C / 248°F	B	25	1-1/2"	YES WITH CONTROL
ELV290W-06	3/4	115	1	10.4	24	120°C / 248°F	B	6	1-1/2"	YES WITH CONTROL
ELV290HVW	3/4	208-230	1	5.3	13	105°C / 221°F	B	25	1-1/2"	YES WITH CONTROL
ELV290HVW-06	3/4	208-230	1	5.3	13	105°C / 221°F	B	6	1-1/2"	YES WITH CONTROL

ELV-W-Series Technical Data

SYSTEM	MIN. SUMP SIZE	Ø18" X 30"
	CONTROL PANEL	TYPE 4X ENCLOSURE
	ALARM	TYPE 1 ENCLOSURE
	WEIGHT	
	ELV250W	40 LBS / 18.1 KG
	ELV280W / ELV280HVW	46 LBS / 20.9 KG
	ELV290W / ELV290HVW	47 LBS / 21.3 KG
PUMP	IMPELLER	VORTEX ENGINEERED POLYMER
	SOLIDS HANDLING SIZE	
	EV250	1/2"
	EV280, EV280HV, EV290, EV290HV	3/4"
	PAINT	POWDER COAT
	MAX LIQUID TEMP	60°C / 140°F
	MAX STATOR TEMP	CLASS B 130°C / 266°F
	THERMAL OVERLOAD	
	EV250, EV280, EV280HV, EV290HV	105°C / 221°F
	EV290	120°C / 248°F
	MOTOR HOUSING/ VOLUTE	CLASS 25 CAST IRON
	SHAFT	STAINLESS
	HARDWARE	STAINLESS
	O-RINGS	BUNA-N
	SHAFT SEAL	
	EV250	ENGINEERED DOUBLE LIP WITH STAINLESS STEEL SPRINGS
	EV280, EV280HV, EV290, EV290HV	CARBON CERAMIC
	WEIGHT	
	EV250	23 LBS / 10,4 KG
	EV280, EV280HV, EV290, EV290HV	30 LBS / 13,6 KG
PUMP CERTIFICATIONS	SSPMA, cCSAus (60 HZ MODELS ONLY)	

ELV-W-Series Specifications

1.01 GENERAL

The contractor shall provide labor, material, equipment, and incidentals required to provide _____ (QTY) centrifugal pumps as specified herein. The pump models covered in this specification are ELV-W-Series single-phase pumps. The pump furnished for this application shall be model _____ as manufactured by Liberty Pumps.

2.01 OPERATING CONDITIONS

Each submersible pump shall be rated at _____ hp, _____ volts, single-phase, 60 Hz, 3450 RPM. The unit shall produce _____ GPM at _____ feet of total dynamic head.

The submersible pump shall be capable of handling water with _____ solids handling capability. The submersible pump shall have a shut-off head of _____ feet and a maximum flow of _____ GPM @ 5 feet of total dynamic head.

The manual pump is connected to a control that has the ability to prevent oil from being pumped from the vault. This same control unit will activate an alarm when an oil "film" is detected or when a high water condition exists. The system will continue to monitor and remove water from the vault even if an oil condition is detected.

3.01 CONSTRUCTION

Each centrifugal sump pump shall be equal to the  Certified ELV-W-Series pumps as manufactured by Liberty Pumps, Bergen NY. The castings shall be constructed of class 25 cast iron. The motor housing shall be oil-filled to dissipate heat. Air-filled motors shall not be considered equal since they do not properly dissipate heat from the motor. All mating parts shall be machined and sealed with a Buna-N O-ring. All fasteners exposed to the liquid shall be stainless steel. The motor shall be protected on the top side with sealed cord entry plate with molded pins to conduct electricity, eliminating the ability of water to enter internally through the cord. The motor shall be protected on the lower side with a unitized ceramic/carbon seal with stainless steel housings and spring or engineered double lip seal with stainless steel springs. The pump shall be furnished with a stainless steel handle.

4.01 ELECTRICAL POWER CORD

The submersible pump shall be supplied with a multi-conductor power cord of 6 or 25 feet in length. It shall be cord type YELLOW or BLACK, UL 16/3 SJE00W 300V 105°C, capable of continued exposure to the pumped liquid. The power cord shall be sized for the rated full load amps of the pump in accordance with the National Electric Code. The power cable shall not enter the motor housing directly but will conduct electricity to the motor by means of a watertight compression fitting cord plate assembly with molded pins to conduct electricity. This will eliminate the ability of water to enter internally through the cord via a damaged or wicking cord.

5.01 MOTORS

Single-phase motors shall be oil-filled, capacitor start, class B insulated NEMA B design rated for continuous duty. Since air-filled motors are not capable of dissipating heat, they shall not be considered equal. At maximum load, the winding temperature shall not exceed 135°C un-submerged. Single-phase motors shall have an integral thermal overload switch in the windings for protecting the motor.

6.01 BEARINGS AND SHAFT

An upper and lower ball bearing shall be required. Both the upper and lower bearing shall be a single ball/race type bearing. Both bearings shall be permanently lubricated by the oil that fills the motor housing. The motor shaft shall be made of 300 or 400 series stainless steel.

7.01 SEALS

The pump shall have a unitized carbon ceramic seal with stainless steel housings and spring or engineered double lip seal with stainless steel springs. The motor plate/housing interface shall be sealed with a Buna-N O-ring.

8.01 IMPELLER

The impeller shall be vortex style made of an engineered polymer, with pump out vanes on the back shroud to keep debris away from the seal area. It shall be threaded to the motor shaft.

9.01 CONTROLS

The control unit has three probes and a float ball switch. The pump will activate when the middle probe contacts water, and will remain on until the first, longest probe is no longer in contact with water. A high water alarm is activated when the third or shortest probe contacts water. The system will ignore a small film of oil, however larger volumes of oil will be detected when the alarm probe does not detect water and the float ball activates. The system will continue to operate, removing water, not oil, from the vault even when oil has been detected.

10.01 ALARM

The alarm is an indoor rated alarm panel, powered by a standard 120 VAC wall outlet. The green power LED illuminates when powered. The alarm panel is equipped with audible and visual alarm indication for high oil, high water, and trouble alarm events. A preset level sensor is wired to the control panel from the monitoring area and the control panel auxiliary contacts are wired to the terminal block on the alarm panel. A 9-volt battery (not included) provides battery backup during power outages. Auxiliary contacts can connect to building automation systems (BAS) and phone dialers.

11.01 PAINT

The exterior of the casting shall be protected with powder coat paint.

12.01 SUPPORT

The pump shall have cast iron support legs enabling it to be a freestanding unit.

13.01 SERVICEABILITY

Components required for the repair of the pump shall be shipped within a period of 24 hours.

14.01 TESTING

The pump shall have a ground continuity check and the motor chamber shall be hi-potted to test for electrical integrity, moisture content and insulation defects. The motor and volute housing shall be pressurized and an air leak decay test performed to ensure integrity of the motor housing. The pump shall be monitored for run voltage and current, and checked for noise or other malfunction.

15.01 QUALITY CONTROL

The pump shall be manufactured in an ISO 9001 certified facility.

16.01 WARRANTY

Standard limited warranty shall be 3 years.